

ProTalk Expander

Operating Manual Model B1292

**February, 2006
Rev. 1.00**

 BARNETT ENGINEERING LTD.

215, 7710 5th St. S.E.
Calgary, Alberta, Canada
T2H 2L9

Phone: (403) 255-9544
Fax: (403) 259-2343
www.barnett-engg.com
e-mail: sales@barnett-engg.com

TABLE OF CONTENTS

- 1. Introduction**1
- 2. Installation**2
 - 2.1 Wiring Diagram3
- 3. Operations**4
- 4. Programming (B1225 Mode)**5
 - 4.1 Overview.....5
 - 4.2 Programming Flowchart6
 - 4.3 Programming Examples.....6
- 5. Programming (B1290 Mode)**9
 - 5.1 Overview.....9
 - 5.2 Programming Flowchart10
 - 5.3 Programming Examples.....11
- 6. Specifications**13
- 7. Warranty Statement**.....14
- 8. Appendix A - Mounting Details**.....15

1. INTRODUCTION

The B1292 ProTalk Expander unit provides an additional 8 digital inputs and 4 relay outputs to either the B1225 or B1290 Alarm Reporting Units. Up to 7 expanders can be connected to the master unit for a total of 64 inputs and 32 outputs.

The B1292 is fully compatible with previous expanders and can be intermixed with older units on existing systems. It is housed in a compact 3.5' x 5.5' metal case and features LED indicators to display alarm and relay status information.

A coaxial communications cable connects the master unit to the first expander and each additional expander in a daisy-chain manner. The master unit controls communications on the cable.

2. INSTALLATION

The B1292 features plug-in terminal blocks for all alarm and relay connections.

A coax cable (supplied) connected to the EXP connector is used to establish serial communications with the master unit. Additional expanders are connected in a daisy chain configuration. Expanders must be powered up before or at the same time as the main ProTalk ARU.

| Alarm Connector | | Relay Connector | |
|-----------------|------------------------|-----------------|----------------|
| 1 | Alarm 1 | 1 | Relay 1 NC |
| 2 | Alarm 1 | 2 | Relay 1 Common |
| 3 | Alarm 1 | 3 | Relay 1 NO |
| 4 | Alarm 1 | 4 | Relay 2 NC |
| 5 | Alarm 1 | 5 | Relay 2 Common |
| 6 | Alarm 1 | 6 | Relay 2 NO |
| 7 | Alarm 1 | 7 | Relay 3 NC |
| 8 | Alarm 1 | 8 | Relay 3 Common |
| 9 | Ground | 9 | Relay 3 NO |
| 10 | Ground | 10 | Relay 4 NC |
| 11 | Ground | 11 | Relay 4 Common |
| 12 | Power +11.5 to +28 VDC | 12 | Relay 4 NO |

| Expander Communications (2) | |
|-----------------------------|--------|
| Inner | Signal |
| Outer | Ground |

There are two connectors for expander communications (EXP); both connectors operate in the same way. It does not matter which connector is used for attaching the previous or next device in the system.

Do not apply power to the EXP connector.

3.1 WIRING DIAGRAM

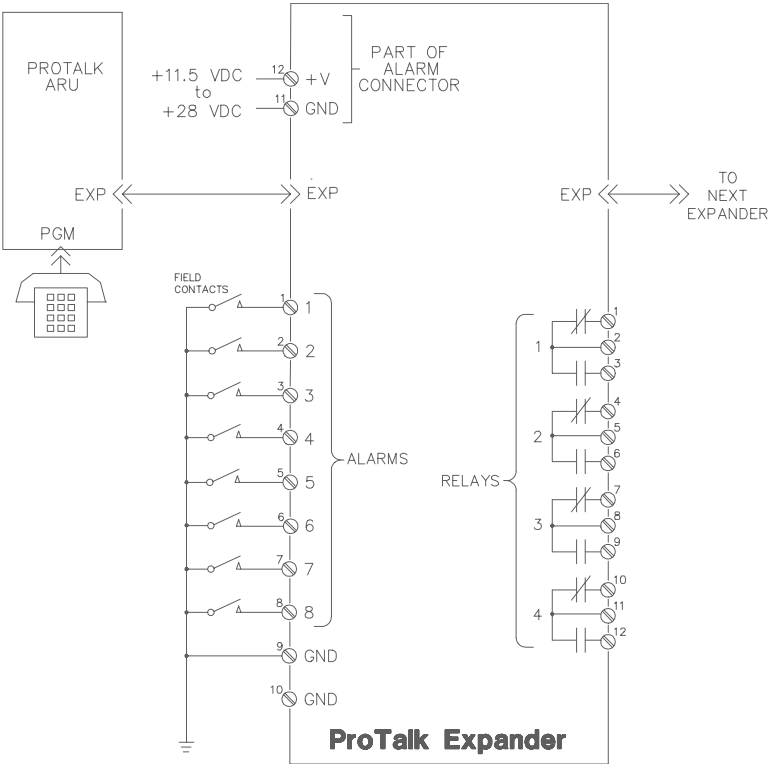

* The coax expander cable between the ProTalk Plus and the first expander is different than the cable between expanders.

Figure 1 ProTalk Expander Wiring Connections

3. OPERATIONS

The front panel of the B1292 is shown in Figure 2. The front panel indicators assist in verifying the correct operation of the unit. Detailed information on the overall operation of the alarm system that the expander is being used with is contained in the manual for the main reporting unit.

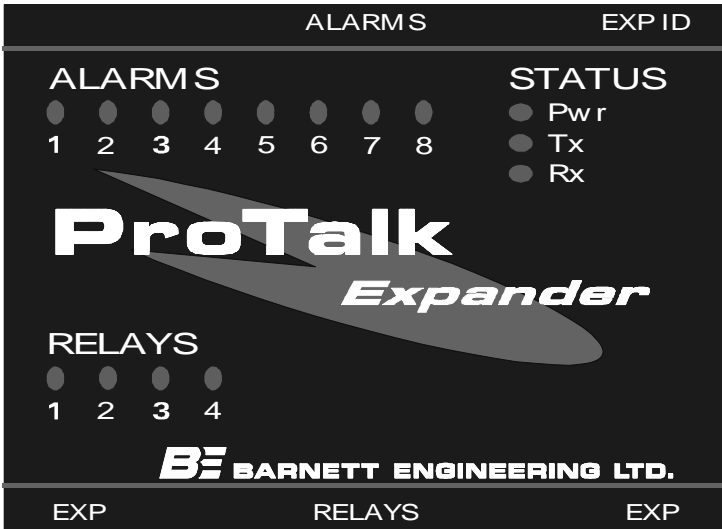

Figure 2 ProTalk Expander Front Panel

| | |
|------------------------|---|
| Alarm LEDs | The Alarm LED is on when the associated input is in the alarm state. When connected to a B1290, unacknowledged alarms will be flashing and any that have been acknowledged will be on solid. |
| Relay LEDs | The Relay LEDs light whenever the associated relay is on. |
| PWR LED | The PWR LED indicates that power has been applied to the unit as well as the operational mode that it is configured for. Solid indicates that the unit is in B1225 mode, flashing indicates B1290 mode. |
| Tx LED unit. | The Tx LED lights when the B1292 is sending to the main |
| Rx LED bus. | The Rx LED lights when a message are present on the serial |

4. PROGRAMMING (B1225 MODE)

4.1 OVERVIEW

Each expander has a unique ID number (1-7) set on the rotary switch. This ID number is used during programming to select the desired unit. If the expander ID is changed, the system must have power removed and then reapplied before the new address is recognized.

The operational mode of the B1292 will automatically be set when the unit is programmed. A solid PWR LED indicates B1225 mode.

Before programming the expander the “Number of Expanders” and “Expander Site Voice” must be set on the B1225. The expander is programmed through the B1225 with the handset.

At the “Enter Program Code” prompt, the different functions of the expander can be selected by entering their program code. When an individual expander is accessed, its configuration is read into the B1225 over the expander serial connection. At this point, if necessary, the operational mode of the expander is automatically set B1225 mode. When the program phone is hung up the new configuration is written back to the expander and stored in non-volatile FLASH memory.

Although expanders are shipped with a “default” configuration, the Alarm Voices must be programmed.

A description of the programming procedure for a B1225 expander is given below. Use these codes in conjunction with the programming manual for the B1225. N is the expander ID number of the unit being programmed.

4.2 PROGRAMMING FLOWCHART (B1225 MODE)

[N] = expander ID number; where [X] appears, user data is entered.

[#][N][1][*][*] Voices ————— [2][*][*] Record
[*][*] Next

[#][N][4][*][*] Alarm On/Off DTMF — [X][*][*] Alarm Number
└── [X][*][*] Change
 [#][*][*] Clear
 [*][*] Next

[#][N][5][*][*] Alarm Debounce ————— [X][*][*] Change
[*][*] Next

[#][N][6][*][*] Alarm Format ————— [0][*][*] NO
[1][*][*] NC

[#][N][8][*][*] Relay On/Off DTMF — [X][*][*] Change
[#][*][*] Clear
[*][*] Next

[#][N][9][*][*] Relay Format ————— [X][*][*] Change
[*][*] Next
Relay On Timer
[X][*][*] Change
[*][*] Next

4.3 PROGRAMMING EXAMPLES

[#][N][1][*][*] VOICES

The site identifier and each of the 8 alarm inputs are programmed for the expander in this section. The alarm messages are identified as N.1 to N.8 instead of 1 to 8 in the master B1225.

Example: You want to program the site identifier in the first expander to say “Delta Compressor”

ARU: ENTER PROGRAM CODE
YOU: #11** (selecting voice message)
ARU: EXPANDER1 SITE IS ...
YOU: 2** (selecting change)
ARU: BEEP - (record light comes on)
YOU: (speaking) DELTA COMPRESSOR
ARU: EXPANDER 1 SITE IS DELTA COMPRESSOR
YOU: **
ARU: ALARM NUMBER 1 point 1 IS ... (on to the alarm messages)

#N4 ALARM ON/OFF DTMF**

The DTMF on and off strings will be programmed for the expander specified. As in the voice message programming section, the expander and alarms will be announced as N point 1 to N point 8

Example: You want to program the second input in expander 1 to have a DTMF ON code of 123 and an off code of 456.

```

ARU: ENTER PROGRAM CODE
YOU: #14**
ARU: ENTER ALARM NUMBER
YOU: 2**
ARU: ALARM NUMBER 1 point 2 DTMF ON CODE IS ...
YOU: 123**
ARU: ALARM NUMBER 1 point 2 DTMF ON CODE IS 123
YOU: **
ARU: DTMF OFF CODE IS ...
YOU: 456**
ARU: DTMF OFF CODE IS 456
YOU: **
ARU: ENTER ALARM NUMBER

```

#N5 ALARM DEBOUNCE**

Alarm delay time (debounce time) can be set for each expander and must be between 0.1 and 9.9 seconds. One debounce time is used for all of the inputs on a particular expander. Each expander may have a different time. The input must remain active for this period of time in order for it to be considered a change of state.

Example: The debounce time for expander 2 is to be set at 3 seconds.

```

ARU: ENTER PROGRAM CODE
YOU: #25**
ARU: EXPANDER 2 ALARM DELAY IS 0.5 SECONDS
YOU: 30**
ARU: EXPANDER 2 ALARM DELAY IS 3.0 SECONDS
YOU: **

```

#N6 ALARM FORMAT**

Each alarm input on an expander can be programmed to be Normally Open (N.O. – requiring a ground closure to become active) or Normally Closed (N.C. - requiring a release from ground to become active). The ALARM FORMAT must be a 0 for N.O. contacts or a 1 for N.C. contacts.

Example: The inputs for expander two are to be set for normally closed inputs.

```

ARU: ENTER PROGRAM CODE
YOU: #26**
ARU: EXPANDER 2 ALARM FORMAT IS 0
YOU: 1**
ARU: EXPANDER 2 ALARM FORMAT IS 1
YOU: **

```

#N8 RELAY ON/OFF DTMF**

The four relays on each expander can have DTMF on and off codes programmed for remote control. They will be announced as relay numbers X.1 to X.4. The master will interpret DTMF strings from the radio system as ON or OFF controls for the relays. Each string may be up to 8 characters.

Example: The control codes for the output relays in expander one are to be programmed. The first relay will have an ON code of 789 and an OFF code of 321

```

ARU: ENTER PROGRAM CODE
YOU: #18**
ARU: RELAY NUMBER 1 point 1 DTMF ON CODE IS EMPTY
YOU: 789**
ARU: RELAY NUMBER 1 point 1 DTMF ON CODE IS 789
YOU: **
ARU: RELAY NUMBER 1 point 1 DTMF OFF CODE IS EMPTY
YOU: 321**
ARU: RELAY NUMBER 1 point 1 DTMF OFF CODE IS 321
YOU: **

```

#N9 RELAY FORMAT**

This will specify the type of relays being used for each expander. The relays will be announced as N.1 to N.4. Each relay may be of a different format. (0=standard, 1=latched, 2=timed).

: Note: Relay Format 1 (Latched) is not supported in the B1292 and will default to “standard” if selected.

Example: Relay one in expander one is to be set as a timed relay.

```

ARU: ENTER PROGRAM CODE
YOU: #19**
ARU: RELAY NUMBER 1 point 1 FORMAT IS ZERO
YOU: 2**
ARU: RELAY NUMBER 1 point 1 FORMAT IS TWO
YOU: **

```

5. PROGRAMMING (B1290 MODE)

5.1 OVERVIEW

Each expander is assigned a unique ID number (1-7) using a rotary switch. This ID number is used during programming to select the desired unit.

If the expander ID is changed, the system must have power removed and then reapplied before the new address is recognized.

The operational mode of the B1292 will automatically be set when the unit is programmed. A flashing PWR LED indicates B1290 mode.

Before programming the expander the “Number of Expanders” and “Expander Site Voice” must be set on the B1290.

Expanders connected to a B1290 may be programmed through the B1290 handset, remotely or using PC Configuration Software.

All the expander’s programmed parameters, aside from the voice messages, are stored in the main ProTalk Plus and are downloaded on power-up. The B1292 will switch to B1290 Mode when this download is complete.

The following program codes are valid for the B1292 expander when in B1290 mode. Use these codes in conjunction with the programming manual for the B1290. N is the expander ID number of the unit being programmed.

5.2 PROGRAMMING FLOWCHART (B1290 MODE)

(N) = expander ID number, where (X) appears, user data is entered.

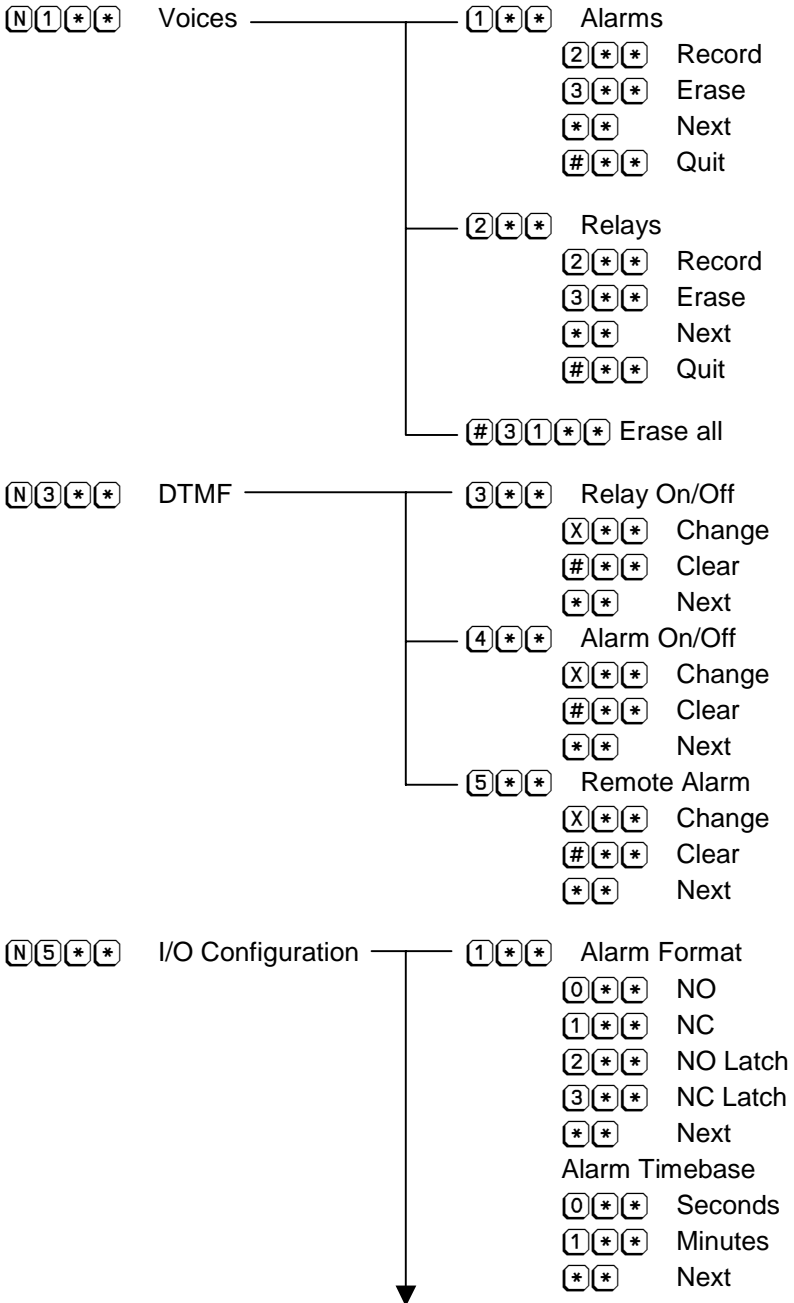

| | |
|---|---------------------------|
| | Alarm Debounce |
| | (X)(*)(*) Change |
| | (*)(*) Next |
| | (#)(*)(*) Quit |
| — | (2)(*)(*) Using Directory |
| | (0)(*)(*) Off |
| | (1)(*)(*) Dir A |
| | (2)(*)(*) Dir B |
| | (3)(*)(*) Dir C |
| | (4)(*)(*) Dir D |
| | (*)(*) Next |
| — | (3)(*)(*) Relay Timebase |
| | (0)(*)(*) Seconds |
| | (1)(*)(*) Minutes |
| | Relay Timer |
| | (0)(*)(*) Not Timed |
| | (X)(*)(*) Timed |
| | (*)(*) Next |

5.3 PROGRAMMING EXAMPLES

(N)1(*)(*) VOICES

The site identifier and each of the 8 alarm and 4 relay voices are programmed for the expander in this section. Voice messages are of variable length and are terminated when the B1290 detects a period of silence.

Example: You want to program the site identifier in the first expander to say “Delta Compressor”

```

ARU: ENTER PROGRAM CODE
YOU: 11*** (selecting voice message)
ARU: ENTER VOICE CODE
YOU: 1***
ARU: EXPANDER 1 SITE IS ...
YOU: 2*** (selecting change)
ARU: BEEP
YOU: (speaking) DELTA COMPRESSOR
ARU: EXPANDER 1 SITE IS DELTA COMPRESSOR
YOU: ***
ARU: EXPANDER 1 ALARM 1 IS ...(on to the alarm messages)

```

(N)(3)(*)(*) DTMF

The Relay On/Off, Alarm On/Off and Remote Alarm Codes are programmed in this section.

Example: You want to program the first Relay in expander 1 to have a DTMF ON code of 321 and an off code of 765.

```

ARU: ENTER PROGRAM CODE
YOU: 13**
ARU: ENTER DTMF CODE
YOU: 3**
ARU: EXPANDER 1 RELAY 1 ON CODE IS ...
YOU: 321**
ARU: EXPANDER 1 RELAY 1 ON CODE IS 321
YOU: **
ARU: OFF CODE IS ...
YOU: 765**
ARU: OFF CODE IS 765
YOU: **
ARU: EXPANDER 1 RELAY 2 ON CODE IS ...

```

(N)(5)(*)(*) I/O CONFIGURATION

This section allows configuration of the expander alarm format, timebases and directory usage. Refer to the B1290 manual for detailed programming instructions.

Example: You want to program Normally Closed Alarm inputs on expander 2 with the first alarm pointing to directory D.

```

ARU: ENTER PROGRAM CODE
YOU: 25**
ARU: ENTER CONFIGURATION CODE
YOU: 1**
ARU: EXPANDER 2 ALARM FORMAT IS 0
YOU: 1**
ARU: EXPANDER 2 ALARM FORMAT IS 1
YOU: #**
ARU: ENTER CONFIGURATION CODE
YOU: 2**
ARU: EXPANDER 2 ALARM 1 IS DIRECTORY A
YOU: 4**
ARU: EXPANDER 2 ALARM 1 IS DIRECTORY D
YOU: **
ARU: EXPANDER 2 ALARM 2 IS DIRECTORY A

```

6. SPECIFICATIONS

| | |
|------------------------|--|
| Alarm Inputs | 8, optically isolated, 2mA to operate, ground closure required |
| Control Outputs | 4 independent form C outputs controlled by programmable codes, On/Off or timed modes Rated: 1 Amp at 30 Volts |
| Adjustments | Rotary DIPswitch for setting the expander ID number |
| Power | +11.5 VDC to +28 VDC 50 mA standby, 200mA max at 12V |
| Environment | -40°C to + 60°C, 95% relative humidity, non-condensing |
| Physical | 4.5" x 5.5" x 2" Plug-in terminals |

7. WARRANTY STATEMENT

Barnett Engineering Ltd. warrants that all equipment supplied shall be free from defects in material or workmanship at the time of delivery. Such warranty shall extend from the time of delivery for a period of one year. Buyer must provide written notice to Barnett Engineering Ltd. within this prescribed warranty period of any defect. If the defect is not the result of improper usage, service, maintenance, or installation and equipment has not been otherwise damaged or modified after delivery, Barnett Engineering Ltd. shall either replace or repair the defective part or parts of equipment or replace the equipment or refund the purchase price at Barnett Engineering Ltd.'s option after return of such equipment by buyer to Barnett Engineering Ltd.

Shipment to Barnett Engineering Ltd.'s facility shall be borne on account of buyer.

(1) Consequential Damages: Barnett Engineering Ltd. shall not be liable for any incidental or consequential damages incurred as a result of any defect in any equipment sold hereunder and Barnett Engineering Ltd.'s liability is specifically limited to its obligation described herein to repair or replace a defective part or parts covered by this warranty.

(2) Exclusive Warranty: The warranty set forth herein is the only warranty, oral or written, made by Barnett Engineering Ltd. and is in lieu of and replaces all other warranties, expressed or implied, including the warranty of merchantability and the warranty of fitness for particular purpose.

WARNING: This equipment generates, uses and can radiate radio frequency energy and if not installed and used in accordance with the instructions manual, may cause interference to radio communications.

Operation of this equipment in a residential area is likely to cause interference, in which case the user, at his own expense, will be required to take whatever measures may be required to correct the interference.

8. Appendix A - Mounting

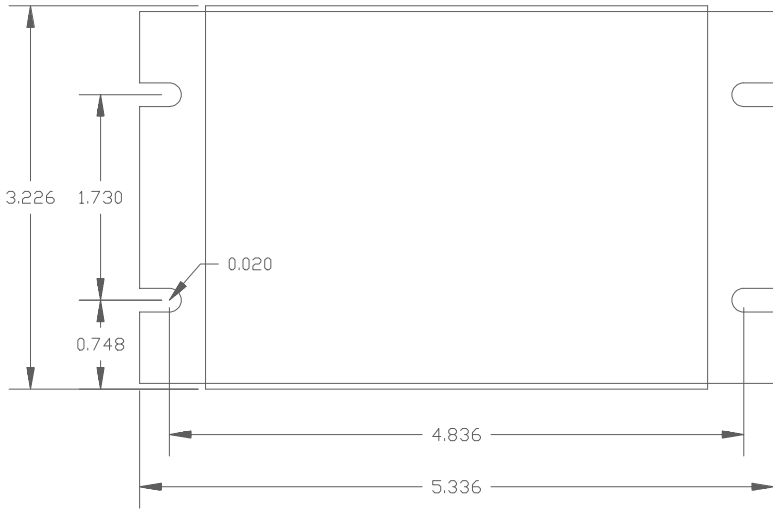

Figure 3 Mounting Detail